

Differential Pressure Gauges

Bayonet Ring Case Stainless Steel
Standard (DiP1Ch) or Liquid Filled (DiP1ChG)

Accuracy Class 1.6

NCS 100 (4")
160 (6")

Models

DiP1Ch
DiP1ChG

This data sheet contains all important features of models DiP1Ch and DiP1ChG with ordering information.

Application

The differential pressure gauges models DiP1Ch and DiP1ChG are used for direct indication of low differential pressure from 0-40 mbar and above at static pressure of 40 bar (600 psi) or optionally 100 bar (1500 psi).

They may be used for measuring fluid or gaseous media, which are compatible with stainless steel 316 Ti, 316 L and Viton. The measuring chambers are flushable, therefore they are insensitive to the accumulation of solid particles. 2x flush and ventilation connections $\frac{1}{8}$ " BSP female are standard supply.

Different electrical accessories can be installed, such as limit-switch contact assemblies and capacitive electrical transformers.

Construction and Function

The measuring system consists of two pressure chambers, each fitted with a measuring diaphragm which are connected by a connecting rod. The space between the two diaphragms is liquid-filled to compensate the static pressure.

In case of balanced pressure both measuring diaphragms are in their position of equilibrium. In case of differential pressure a force is created on the diaphragms which causes a deflection in direction of the lower pressure.

The connecting rod transfers this deviation of the measuring diaphragms to the transfer-lever that is mounted on the measuring shaft. The measuring shaft causes a rotation proportionally to the differential pressure which is transmitted by the movement to an analogous pointer move between 0 and 270°.

In case of one-sided force acting on the measuring system and exceeding the measuring range the overpressure protection becomes active. Due to the overpressure a collar mounted on the connection rod will be pressed against an internal O-ring which prevents the transferring of the overpressure to the opposite diaphragm. That way two separated pressure rooms are built up. Inside of the liquid filled room between the overloaded diaphragm and the O-ring a counter pressure equivalent to the overpressure will be built up which protects the strained diaphragm. The forces acting on the diaphragm will be compensated.



DiP1Ch 100-3-R (tube mounting type)

Functional Diagram

1. Connecting rod
2. O-rings, overpressure protection
3. Measuring diaphragms
4. Movement
5. Measuring shaft
6. Transfer lever
7. Liquid for pressure transfer

HP = Higher Pressure
LP = Lower Pressure

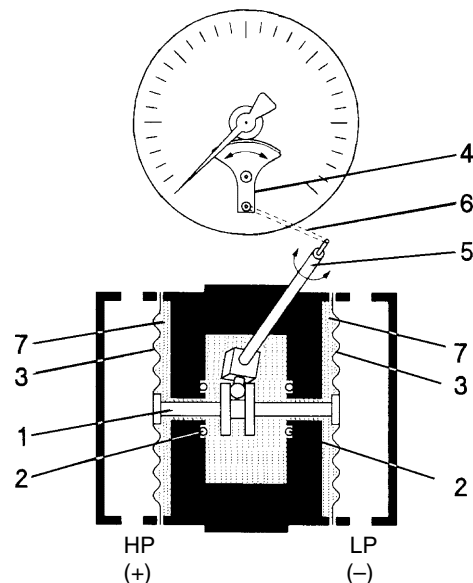

General Features

Nominal Case Sizes (NCS)

100 (4") , 160 (6")

Accuracy Class (EN 837-3)

1.6

Pressure Ranges (EN 837-3)

NCS 100 (4"): 0-0,6 bar (0-10 psi) to 0-25 bar (0-400 psi)

NCS 160 (6"): 0-40 mbar (0-16 "WC) to 0-25 bar (0-400 psi)

also the corresponding standard vacuum and compound ranges $\geq -40/+60$ mbar

Pressure Limitations

Max. static pressure PN 40 (600 psi);

one-sided overrange protected up to permissible PN;

vacuum protected

Temperature Limitations

Ambient temperature $-20\text{ }^{\circ}\text{C}$ up to $+80\text{ }^{\circ}\text{C}$ ($-4\text{ }^{\circ}\text{F}$ up to $+176\text{ }^{\circ}\text{F}$)

Medium temperature max. $+100\text{ }^{\circ}\text{C}$ ($+212\text{ }^{\circ}\text{F}$)

Reference Temperature

$+20\text{ }^{\circ}\text{C}$ ($+68\text{ }^{\circ}\text{F}$)

Temperature Caused Error

Approx. 0.3%/10 K ($18\text{ }^{\circ}\text{F}$)

Protection Type (EN 60529 / IEC 529)

Model DiP1Ch = IP 54 / model DiP1ChG = IP 65

Standard Configuration

Connection

Bottom connection,

flange similar to DIN 19213, $\frac{7}{16}$ " UNF with 2 x $\frac{1}{2}$ " BSP female, marked with "+" (HP) and "-" (LP), each with flush and ventilation

connection $\frac{1}{8}$ " BSP, with sealing plug

Pressure chambers

Stainless steel 316 L (1.4404)

Diaphragms

0-40 to 0-400 mbar (**0-16 to 0-160 "WC**): stainl. steel 316 Ti (1.4571)

0-0.6 to 0-25 bar (**0-10 to 0-400 psi**): NiCrCo-Alloy (Duratherm)

Intermediate plate

AlCuMgPb - HART COAT[®]

Filling Liquid Inside of the Measuring System

Silicone oil

O-Rings

Viton (FPM)

Movement

Stainless steel

Dial

Aluminum alloy, black figures, white background

Case and Bayonet Ring

304 stainless steel

Lens

Laminated safety glass

Pointer

Aluminum alloy, black,

external zero point adjustment $\pm 25\%$ of the measuring range

Installation/Mounting

The gauges can be mounted on a wall or a tube. Please indicate which mounting you want. Wall mounting by means of mounting plate respectively tube mounting with accessories for 2"-tube (see drawing next page).

Special Configurations

- Other connection threads upon request
- Special scales (dual ranges or flow ranges)
- Stationary red pointer, internal or external adjustment
- Maximum pressure pointer, external adjustment, acrylic lens
- Max. static pressure PN 100 (**1500 psi**)
- PTFE coated sealings
- Wetted parts hastelloy alloy C
- Installation of electrical accessories like magnetic or inductive limit-switch contact assemblies, or capacitive electrical transformers

Accessories:

3 or 5 spindle valve manifolds, our model numbers 11, 12, stainless steel, see page 4 of this data sheet.

(If required, please order as a separate item.)

How to order:

Model code: **DiP1Ch** (IP 54)
DiP1ChG (IP 65, glycerine filled)

Nominal case size: **100** or **160**

Ordering code
wetted parts: **-3** (stainless steel)

Code letter for
mounting type: **-R** for tube mounting and
-W for wall mounting

Pressure range: according to EN 837-3,
i.e. 0-60 psi or **0-4 bar**

Special configurations: (see above)

Examples for ordering information:

- DiP1Ch 100-3-R, 0-6 bar
- DiP1ChG 160-3-W, 0-100 mbar

Dimensional Data and Weights

Pressure ranges from 0-0.6 to 0-25 bar (0-10 to 0-400 psi), NCS 100 and 160 mm (4 and 6 ")

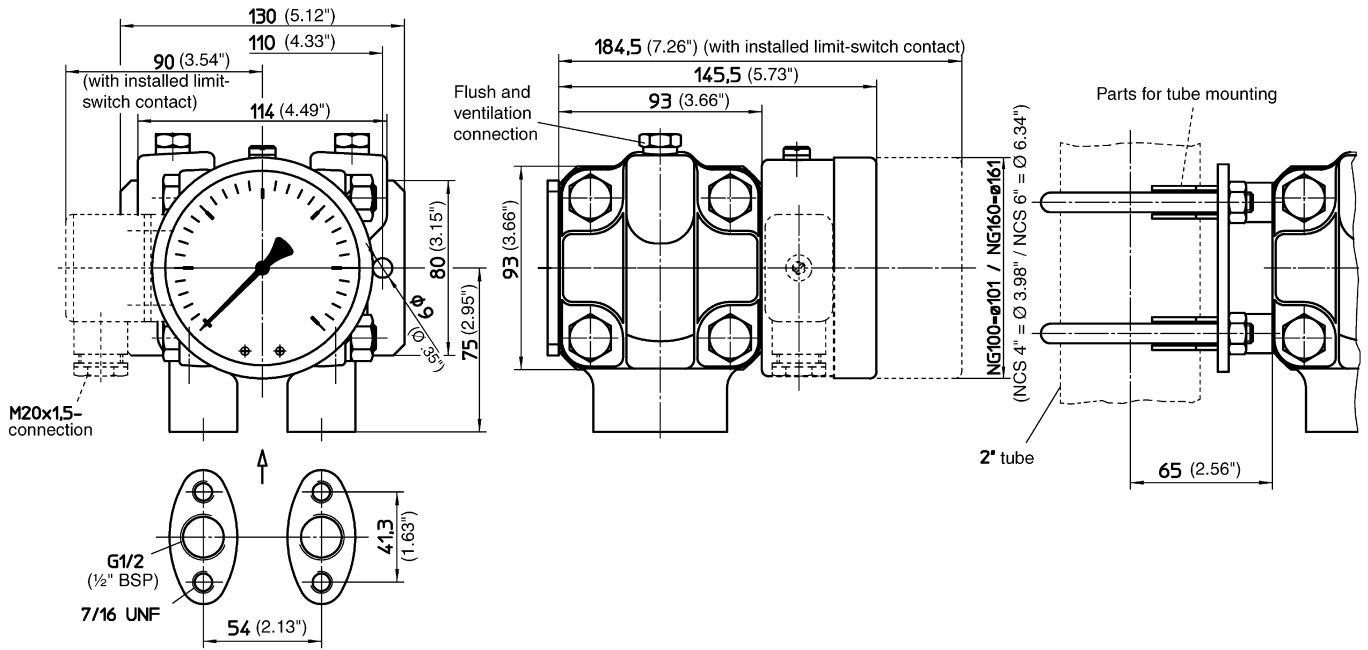

Pressure ranges from 0-40 to 0-400 mbar (0-16 to 0-160 "WC), NCS 160 (6 ")

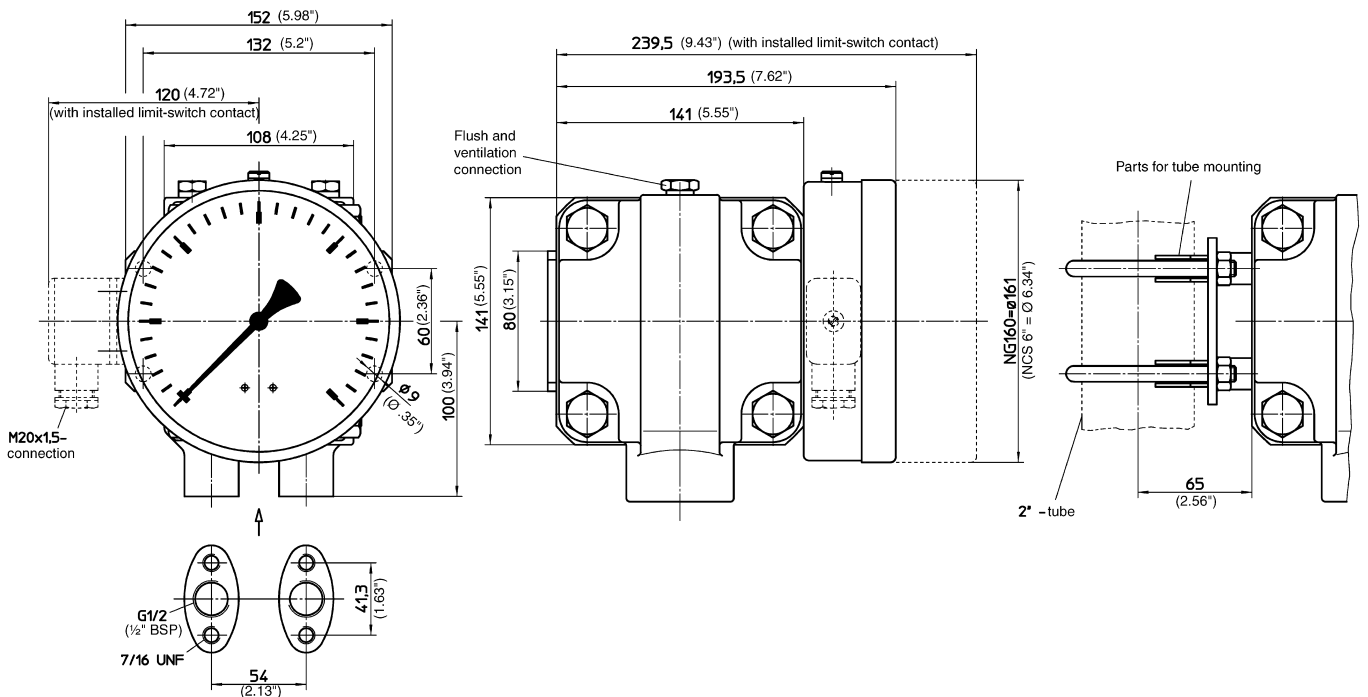

Weights

Model	Pressure ranges	Weights
DiP1Ch 100		6.00 kg (13.25 lb)
DiP1ChG 100	0-0.6 bar to 0-25 bar	6.60 kg (14.57 lb)
DiP1Ch 160	0-10 psi to 0-400 psi	6.60kg (14.57 lb)
DiP1ChG 160		7.60 kg (16.78 lb)
DiP1Ch 160	0-40 mbar to 0-400 mbar	12.00 kg (26.49 lb)
DiP1ChG 160	0-16" WC to 0-160 "WC	13.00kg (28.70 lb)

Manifolds

for Differential Pressure Gauges DiP1Ch / DiP1ChG

Models **11 and 12**

3-Valve Manifold Model No. 11

PN 400, DN 5

1	Body	316 Ti (1.4571), forged
2	Valve seats	316 Ti (1.4571), screwed-in
3	Valve stem	316 Ti (1.4571)
3.1	Valve cone	316 Ti (1.4571), crimped, movable
4	Bonnet	316 Ti (1.4571)
5	Scraper ring	Novapress®
6	Packing	PTFE up to +200 °C
7	Gland	316 Ti (1.4571)
8	Union Nut	316 Ti (1.4571)
9	Handwheel	Plastic
10	Cap nut	304 stainless steel (1.4301)
13	Sealing	316 Ti (1.4571)

Connection

Inlet:
Compression fitting 316 Ti (1.4571) for tube-Ø 12 mm (.47"), line L, G 3/8",
Outlet:
Flange DIN19213, form B1

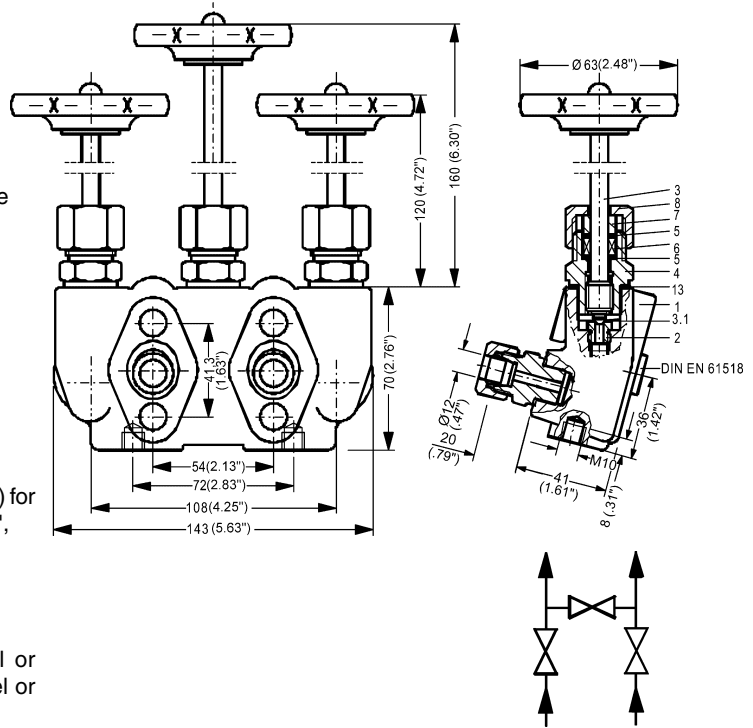

Special Configurations

- Mounting assembly consisting of 4 screws carbon steel or stainless steel* 7/16-20 UNF x 2 1/8", 4 washer carbon steel or stainless steel*, 2 gaskets PTFE
* (For O₂ use stainless steel only!)
- Free of grease and oil for oxygen service, max. temperature +60 °C (140 °F)
- Temperature resistant up to +300 °C (+572 °F)
- 1 socket wrench with locket handle alloy steel (brown-finish)

5-Valve Manifold Model No. 12

PN 400, DN 5

1	Body	316 Ti (1.4571), forged
2	Valve seat	316 Ti (1.4571), screwed-in
3	Valve stem	316 Ti (1.4571), roll sealed
3.1	Valve cone	316 Ti (1.4571), crimped, movable
4	Bonnet	316 Ti (1.4571)
5	Scraper ring	Novapress®
6	Packing	PTFE up to +200 °C
7	Gland	316 Ti (1.4571)
8	Union Nut	316 Ti (1.4571)
9	Handwheel	Plastic
10	Cap nut	304 stainless steel (1.4301)
13	Sealing	316 Ti (1.4571)

Connection

Inlet/blow-off:
Compression fitting 316 Ti (1.4571) for tube-Ø 12 mm (.47"), line L, G 3/8",
Outlet:
Flange DIN19213, form B1

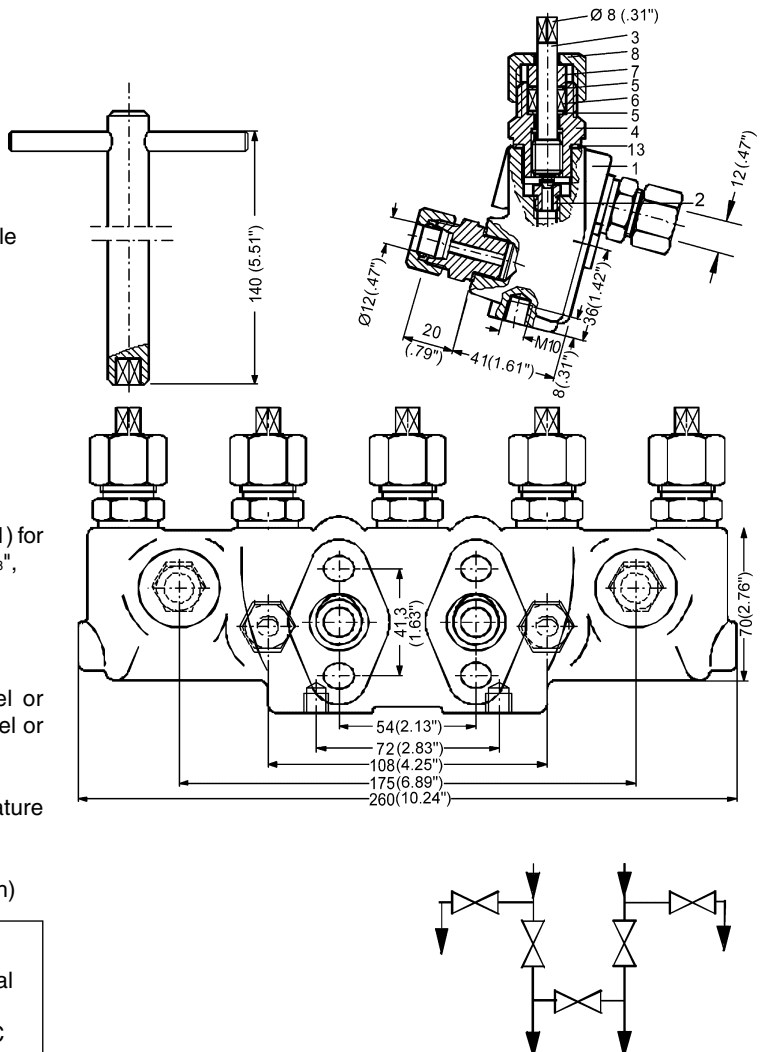

Special Configurations

- Mounting assembly consisting of 4 screws carbon steel or stainless steel* 7/16-20 UNF x 2 1/8", 4 washer carbon steel or stainless steel*, 2 gaskets PTFE
* (For O₂ use stainless steel only!)
- Free of grease and oil for oxygen service, max. temperature +60 °C (140 °F)
- Temperature resistant up to +300 °C (+572 °F)
- 1 socket wrench with locket handle alloy steel (brown-finish)

How to Order:

Please specify model number and, as far as required, special configurations, e.g.:
5-valve-manifold no. 12, temperature resistant up to +300 °C