

Differential Pressure Gauges

Bayonet ring case, stainless steel

without (DiP3Ch) or with glycerine filling (DiP3ChG)

Kl. 2.5
NCS 100

DiP3Ch
DiP3ChG

This data sheet contains all essential details of the available versions model DiP3Ch resp. DiP3ChG with information on the ordering code.

Application

Differential pressure gauges model DiP3Ch resp. DiP3ChG are for direct indication of low differential pressures for 1 bar and above with high static pressure PN 100.

They are suitable for gaseous or liquid media, that do not corrode 1.4404, 1.4571 (316 stainless steel) and Viton.

Construction and Measuring Principle

The pressures that have to be compared, operate hydraulically via separating membrane on the measuring membrane. During pressure equality the measuring membrane is in rest position. During pressure difference a force occurs at the measuring membrane. This force effects the move of the membrane towards the low pressure. The measured displacement is being controlled out of the closed measuring unit as rotary motion via a torsion tube and is being transmitted through the closed movement as rotation angle 0 and 270°.

If a one-sided load of the measuring unit occurs beyond the pressure range, the separating membranes reinforce to contour-identical moulded parts of the system case and therefore protect the measuring unit against overloads.

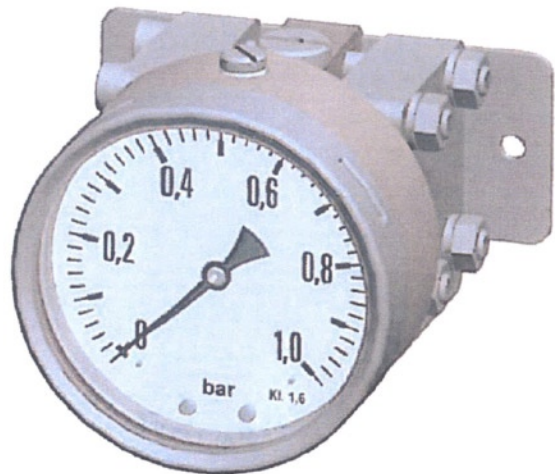

Functional Diagram

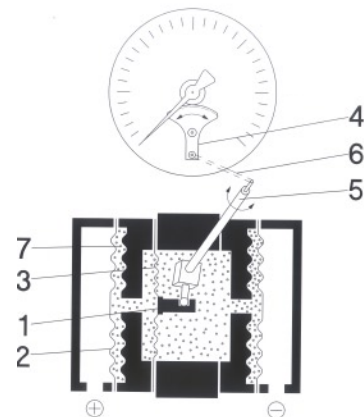

1. Rod
2. Separating membrane
3. Measuring membrane
4. Movement
5. Torsion tube
6. Transfer level
7. Pressure transfer liquid

+ = higher pressure
- = lower pressure

Standard Version Pressure Gauges

Pressure gauges with 2 measuring chambers for differential pressure measurement

Nominal Case Size

100 mm (4")

Accuracy (EN 837)

Class 2.5

(indication accuracy better than ± 2.5 % of full scale value)

Pressure Ranges (EN 837)

NCS 100: 0 / 1 bar ... 0 / 16 bar

Pressure Limitation

max. static pressure PN 100;
one-sided overloadable up to PN;
vacuum-protected

Temperature Resistance

Ambient temperature -20 to +80 °C (-4 °F to 176 °F)

Medium temperature max. +100 °C (212 °F)

Temperature Caused Error

The error caused by temperatures differing from the reference temperature +20 °C (+68 °F) can be up to 0.3 % per each 10 °C (+18 °F).

Protection Type (EN 60529 / IEC 529)

IP 65

Standard Version

DiP3Ch = with case filling (not fillable)

DiP3ChG = filled version, filling fluid glycerine

Process Connections

2 x G 1/4" female

Pressurised Chambers

1.4404 (316 stainless steel)

Membranes

1.4571 (316 stainless steel)

Intermediate Plate

AlMgSiPb - hard-coated

Filling Fluid in the Measuring Unit

Silicone oil

O-Rings

Viton

Movement

Stainless steel

Dial

Aluminum, black figures, white background

Pointer

Micro adjustable pointer

Case and Bayonet Ring

1.4301 (304 stainless steel)

Case Screws

Stainless steel

Window

Laminated safety glass

Mounting

The pressure gauges are suitable for wall- or pipe mounting. Please state the required kind of mounting in case of an order. For wall mounting the mounting of the instrument is carried out via a mounting plate, for 2" pipe mounting it is carried out via 2 mounting brackets (see drawing on next page).

Special Versions

- Other process connections upon request
- Other position of connection upon request
- Special scales (double scale, flow scale)
- Scale with zero point not at the beginning of the scale (as compound gauge scale)
- Adjustable stationary red pointer on laminated safety glass

Ordering Information

Please state in your order:

Basic model: **DiP3Ch** = unfilled (dry)
DiP3ChG = filled,
filling fluid: glycerine

Nominal case size: **100**

Order code for the material of wetted parts: **-3** (standard) = 316SS

Code letters for kind of mounting: **R** for 2" pipe mounting
W for wall mounting

Pressure range: according to EN 837,
e.g. 0-4 bar

Specifics: (see above)

Examples:

- DiP3Ch 100-3, R, 6 bar
- DiP3ChG 100-3, W, 16 bar

Case Configurations, Code Letters, Dimensional Data and Weights

Nominal Case Size 100

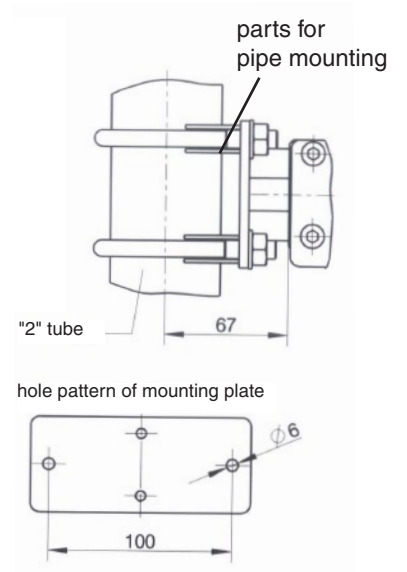
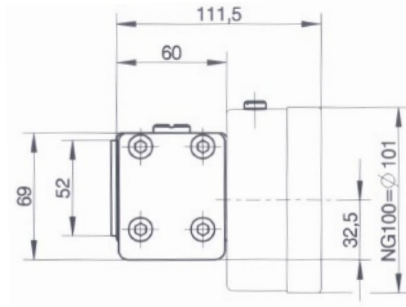
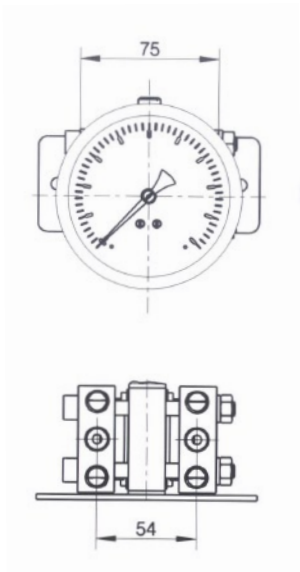

Weights (kg / lb)	
Model	approx. weight (kg / lb)
DiP3Ch 100	2.2 (4.85)
DiP3ChG 100	2.5 (5.51)

Technical changes, replacement of materials and errors excepted
